



GE 630 VP is a ventilation unit containing a cross-flow plate-type heat exchanger, heat pump, air supply and exhaust fans, EU7 air supply bag filter, EU4 exhaust flat filter and complete Optima 300 automatic control with control panel. **GE 630 VPC** has an additional automatic control for cooling.

GE 630 VP/VPC are available with the following accessories:

- Water-based or electric reheating coil for $\varnothing 200$ mm duct
- Water frost thermostat
- Fresh air and exhaust dampers with motor for $\varnothing 200$ mm duct
- Electric preheating coil
- Thermostatic valve or motorised valve
- Fan monitor

Use

GE 630 VP is used for ventilation systems where exhaust and air supply are required and the energy in the exhaust air is to be used to heat the supply air.

The energy is recovered first via the cross-flow plate-type heat exchanger and then the residual energy is recovered by the heat pump, which also contributes to heating the home. GE 630 VPC is used if the heat pump is required to cool the supply air during warm periods.

GE 630 VP/VPC are normally used in homes with an area from 250 to 360 m² and a minimum air exchange of 230 m³/h.

Types

- GE 630 VP - H (right-hand)
- GE 630 VP - V (left-hand)
- GE 630 VPC - H (right-hand - as shown)
- GE 630 VPC - V (left-hand)

Dimensioned sketch

GE 630 VP/VPC
Dimensions in mm

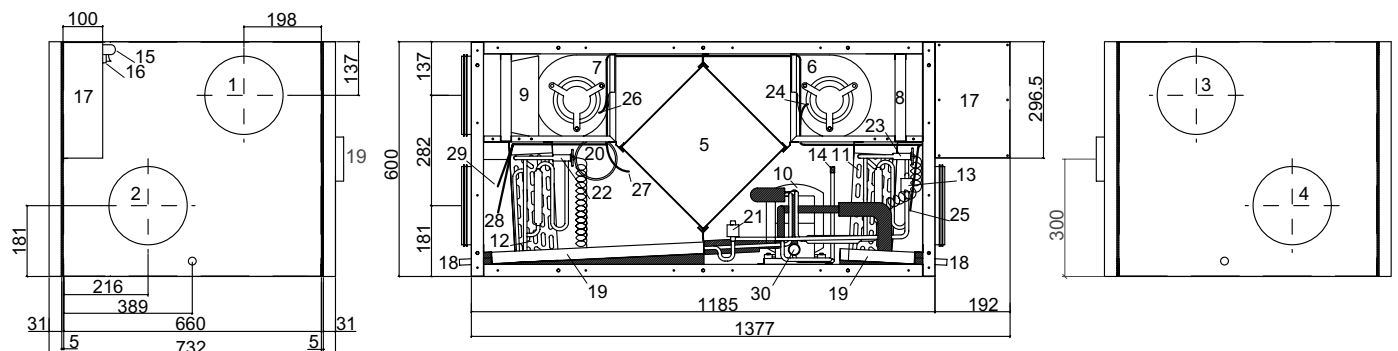

- | | | | |
|------------------------------|----------------------------|---|--|
| 1: Extract air | 9: Bagfilter Supply Air | 17: Terminal box | 24: Sensor Extract air |
| 2: Supply air | 10: Compressor | 18: Drain $\varnothing 15$ | 25: Sensor Incoming air |
| 3: Incoming air (fresh air) | 11: Evaporator | 19: Drip Tray | 26: Sensor Supply air |
| 4: Exhaust air | 12: Condenser | 20: Supply connection duct on rear side | 27: Sensor upstream of Cooling surface |
| 5: Cross-flow heat exchanger | 13: High-pressure governor | 21: Magnetic valve Defrosting | 28: Sensor Cooling surface |
| 6: Extract fan | 14: Process valve | 22: Thermostatic Condenser | 29: Sensor Exhaust air |
| 7: Supply fan | 15: Cable entry | 23: Thermostatic Evaporator | 30: Fourway valve |
| 8: Plainfilter Extract Air | 16: Powerswitch | | |



Output

The output diagram shows the available pressure (P_t) for the duct system, both on the exhaust and supply side. Pressure losses from the unit have been deducted.

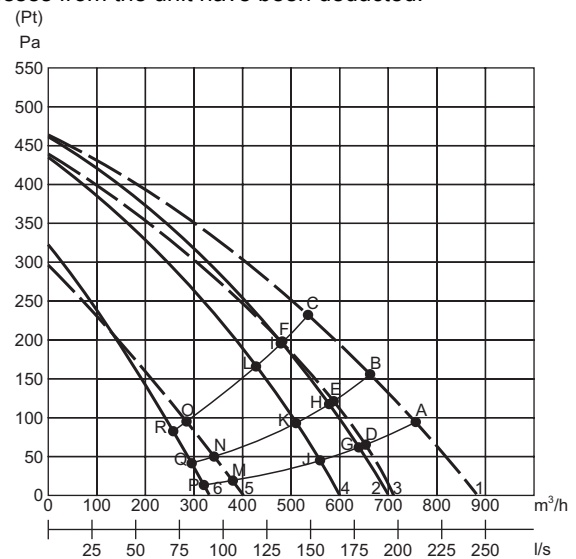

— Supply Air with Bagfilter: 1 = 100%, 3 = 70%, 5 = 40%
 - - - Extract and supply Air with Plainfilter: 1 = 100%, 3 = 70%, 5 = 40%

Input current (Supply Air with Bagfilter)

	A	B	C	D	E	F	G	H	I
Watt	177	175	159	149	145	136	89	88	87

Input current (Extract and Supply Air with Plainfilter)

	J	K	L	M	N	O	P	Q	R
Watt	162	149	124	100	96	89	79	78	75

Technical Data

Electrical Connection

Without electric reheating coil and electric preheating coil

1 x 230V + N + PE 10A, 50 Hz

With electric reheating coil and electric preheating coil

max. 1.2 + 1.0 kW

1 x 230V + N + PE 16A, 50 Hz

Fans with directly coupled motors

D2E 133 DM52

Capacitor

4 µF

Motors, 230V AC:

Standard motors

IEC 38

Insulation class

B

Degree of protection

IP 44

Motor size (2 motors):

RPM

2000

Power input (max. per motor)

200 W

Current consumption (max. per motor)

1.0 A

The fans can be individually set to any speed in all 3 speed-levels.

Working range of heat pump

-15°C/+35°C

Compressor

T6220GK

Power input (max.) 1104 W

Current consumption (max.) 5.1 A

Average output 2690 W

Average power consumption 870 W

Refrigerant R407c

Charge 630 VP/VPC

1050/1200 g

Capacity

The capacity of GE 630 VP/VPC vary with the airflow and fresh air temperature.

Airflow. 400 m³/h.

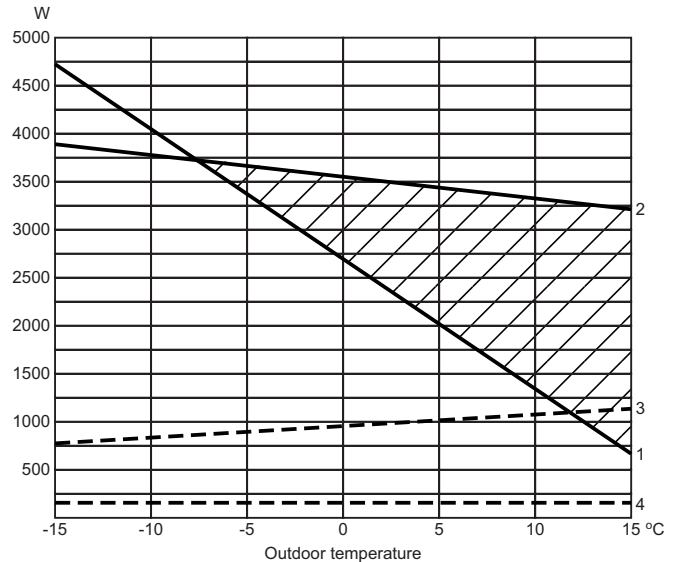

Airflow 650 m³/h.

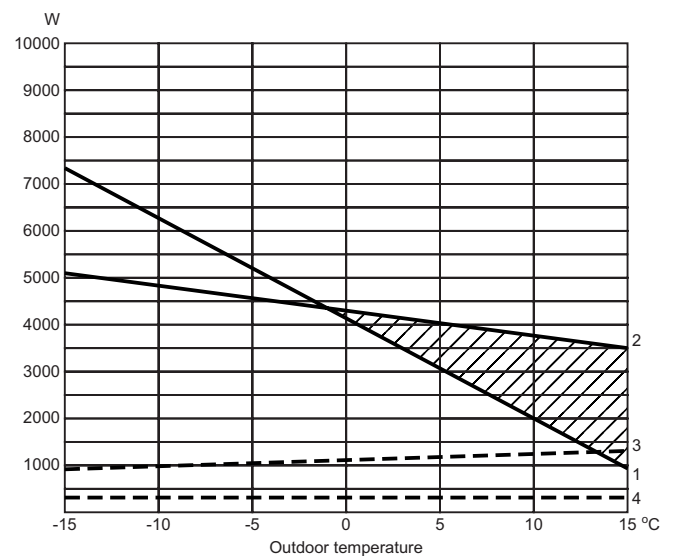

- 1) Energy consumption for heating outdoor air (fresh air) to room temperature 20°C.
- 2) Capacity of the unit.
- 3) Power input with compressor running.
- 4) Power input without compressor running.

The hatched area is the GE 630 VP/VPC's contribution to the roomheating.

Cooling:

With a outside temperature of 26°C, relative humidity of 45 % and 1/1 speed, the cooling power output is 2385W.

Automatic Control

GE 630 VP/VPC are supplied with complete automatic control - Optima 300 AC together with a control panel and display which show the equipment's operating mode and permit easy change of operating settings.

Control panel

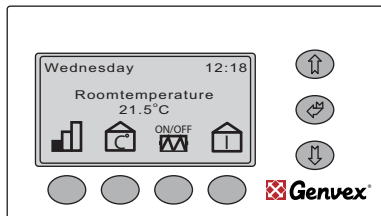

Use this button to change speed between low, medium and high. (Level 1, Level 2, Level 3), or to stop the unit. To stop the unit press the button (3 - 4 seconds) until all levels are switched off. The reheating surface will turn off immediately while the fans will run for about 2 minutes to cool down the reheating surfaces.



Use this button to change the desired room temperature.



Heat pumps of types VP and VPC can be supplied with preheating and reheating surfaces and extra cooling. Enabling will allow these heating and cooling surfaces to switch in if it proves necessary.



Use this button to see all the temperatures in the unit, and press arrow down to see which relays are in operation. This will allow you to gain a quick overview of the unit's operation (see page 4).



If you wish to change the operating settings, press "Arrow up, Arrow down, Enter" to enter the operating menu where these changes can be made.



Press "Arrow down" to change from one menu point to the next. Press "Arrow up" to change from one menu point to the previous one.



If you want to quickly page through the operating menu, you can press "Enter", and this will change the whole page to the next set of menu points.

To change the clock from winter to summer-time hold "Enter" and press "Arrow up" (+1 hour).

To change the clock from summer to winter-time hold "Enter" and press "Arrow down" (-1 hour).

Sound data

Measuring point	1 m in front of unit			Extract duct			Supply duct			
	Airflow rate	1	2	3	1	2	3	1	2	3
		Lo dB			Lwu dB			Lwi dB		
63 Hz	72	72	72	94	94	95	91	91	92	
125 Hz	55	57	59	82	89	89	79	85	88	
250 Hz	51	53	53	80	84	82	89	86	82	
500 Hz	33	37	45	62	70	73	63	72	75	
1000 Hz	27	25	26	56	65	68	53	63	66	
2000 Hz	23	21	26	49	60	64	52	58	61	
4000 Hz	-	-	-	40	55	60	49	53	55	
8000 Hz	-	-	-	32	49	55	44	46	48	
Mean	Lo dB(A)			Lwu dB(A)			Lwi dB(A)			
	45	46	46	73	77	77	73	77	77	

1: Measured at 40% of max. speed with Compressor

2: Measured at 70% of max. speed with Compressor

3: Measured at 100% of max. speed with Compressor



Construction

Main dimensions:

(h x l x d) excl. bosses and electrical box
600 x 1185 x 732 mm

Cabinet structure:

Double-enclosed hot-dip galvanised sheet with 30 mm insulation.
External and internal red powder coating, RAL 3002.

Duct connection:

ø200 mm (nipple dimension) with rubber ring seal

Door:

6 mm screws

Cross-flow plate-type heat exchanger:

Seawater-resistant aluminium

Condensate trays:

Stainless steel

Condensation drain:

Stainless pipe ø15 mm (ext.)

Filters:

Air supply:

EU7 bag filter

Exhaust:

EU4 plain filter

Weight:

143 kg

Flow diagram

Flowdiagram VP

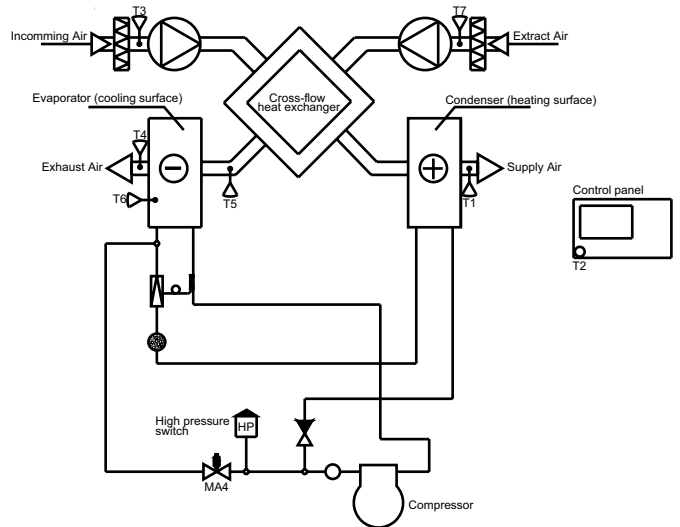

Flowdiagram VPK

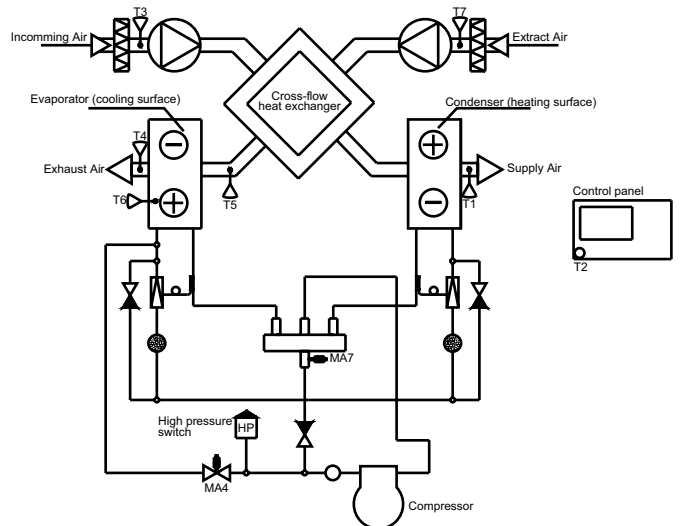

Sensors:

- T1: Supply air
- T2: Room
- T3: Fresh air
- T4: Exhaust air
- T5: Upstream of cooling surface
- T6: Cooling surface
- T7: Extract air
- T8: Freezing water (For water reheating surface)

Solenoid Valves:

- MA4: Defrosting
- MA7: Heating/cooling

Accessories

Water-based and electric heating coils and dampers.